

COLECCIÓN

# volcán

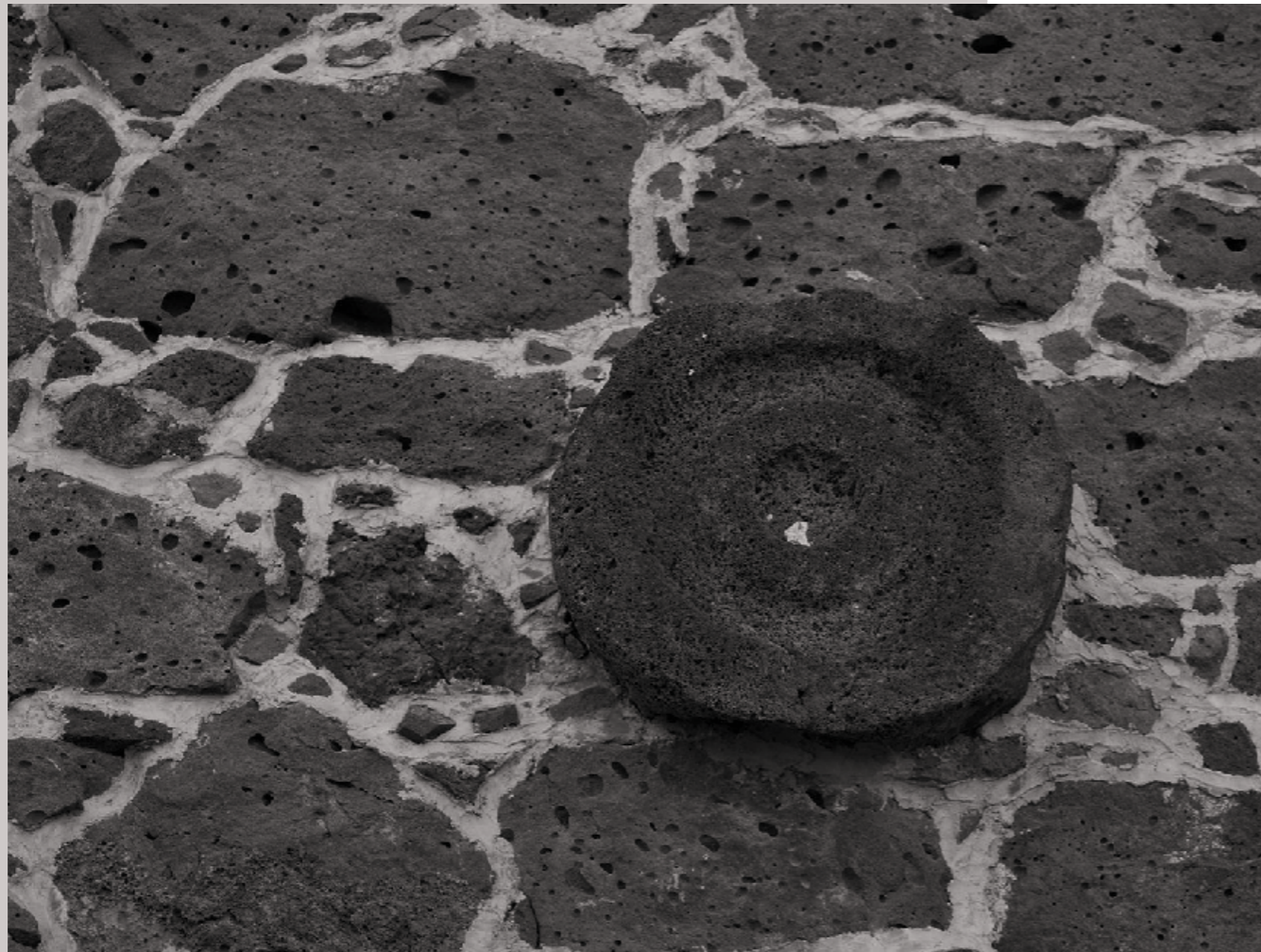

ADN  
studio



**volcán** es la primera colección de muebles de ADN Studio. Diseñados por Paulo Peña y Paulina Hassey, esta colección busca volver a lo básico; es una sutil y depurada interpretación del mueble Moderno arquetípico.

Esta colección está completamente arraigada en la arquitectura, cultura, historia y estética de la Ciudad de México. Cualquiera que ha vivido en esta ciudad sabe del lugar tan importante que juegan en ella los volcanes –esos míticos y majestuosos guardianes que se asoman de pronto y que han inspirado a generaciones de artistas, poetas, creadores de todos tipos y a los millones de mujeres y hombres que habitamos esta enorme ciudad.

COLECCIÓN

volcán

**volcán** toma la riqueza formal usada tanto por los grandes maestros del Modernismo en México, como la usada en los diseños vernáculos antiguos y la destila en líneas limpias, formas geométricas puras que aportan una identidad y personalidad única a cada una de sus piezas.



Esta colección apuesta por el inigualable lujo de lo simple. Reconociendo que parte de la belleza de un objeto se encuentra en la forma en que está construido, los diseños exponen abierta y honestamente la forma en que se arman, siendo cada componente de su construcción un elemento estético del mueble.



# X I T L E

# BUTACA

ADN  
studio

colección volcán







BUTACA

ADN  
studio

colección volcán



# SILLA 1

ADN  
studio

colección volcán



SILLA I

ADN  
studio

colección volcán







ADN  
estudio

colección volcán

# SILLA 2

ADN<sub>studio</sub>

colección volcán



SILLA 2

ADN  
studio

colección volcán





ADN  
studio

colección volcán



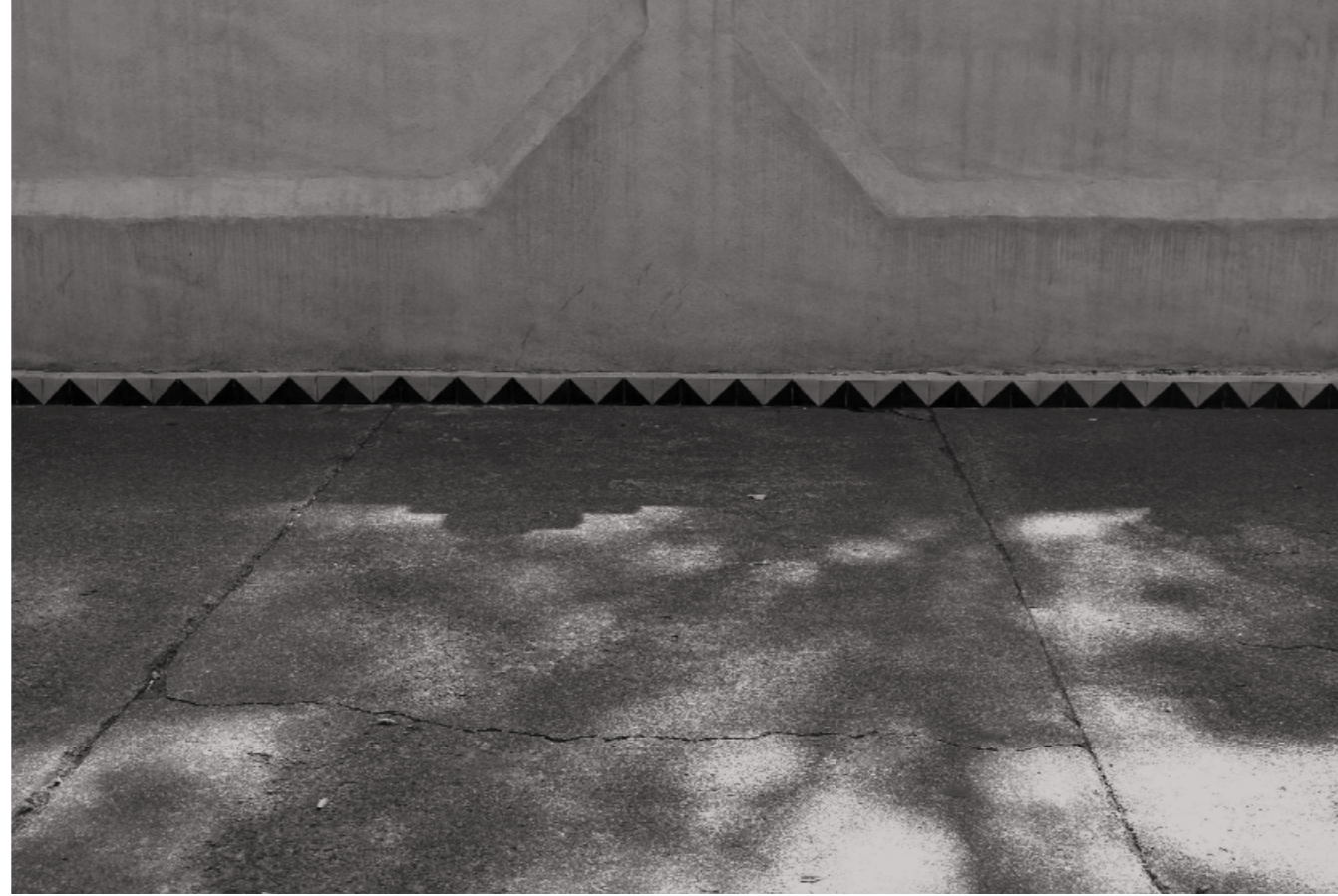

# MESA DE CENTRO



colección volcán

ADN  
studio

MESA DE CENTRO

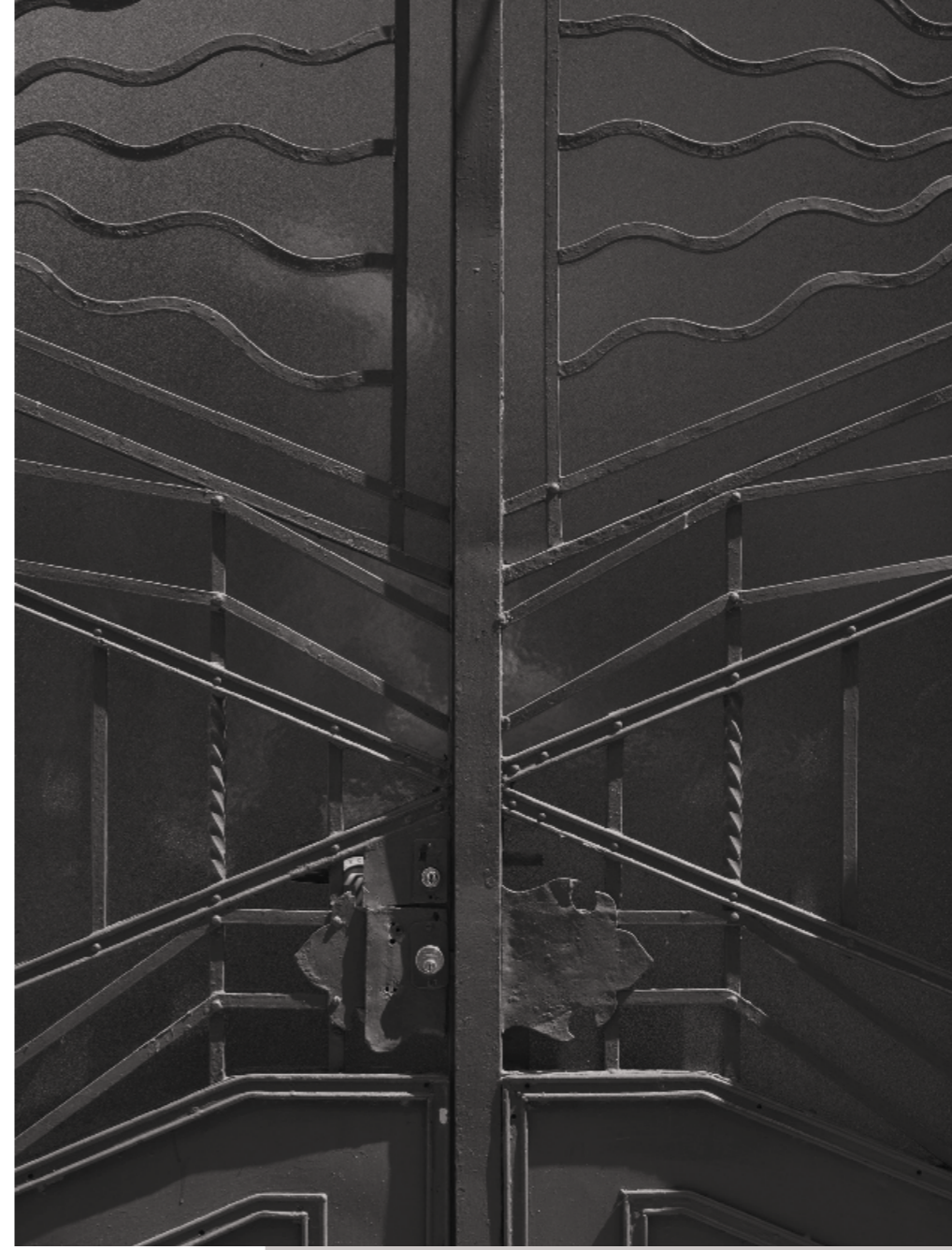



# MESA AUXILIAR

colección volcán





# ESCRITORIO

colección volcán









ADN  
studio

colección volcán

# SILLÓN



ADN  
studio

coleccion volcán

SILLÓN

ADN  
studio

colección volcán





ADN  
studio

colección volcán



# TEOCSA



Usamos solamente materiales nobles. Destacamos su calidez, textura, su riqueza e incluso sus accidentes y todo esto hacen que cada pieza sea única y especial.

Estamos basados completamente en la Ciudad de México. Todos nuestros procesos suceden en colaboración con pequeñas fábricas y artesanos locales.

# MESA AUXILIAR

colección volcán











ADN  
estudio

colección volcán

# MESA DE CENTRO







# MESA

ADN<sub>studio</sub>

colección volcán







ADN  
studio

colección volcán



ADN Studio se guía por la más alta y ambiciosa de las aspiraciones: crear diseños con carácter, con identidad y que logren superar el paso del tiempo.

**volcán** es el resultado de esta aspiración.

# butaca XITLE

ADN  
studio

colección volcán

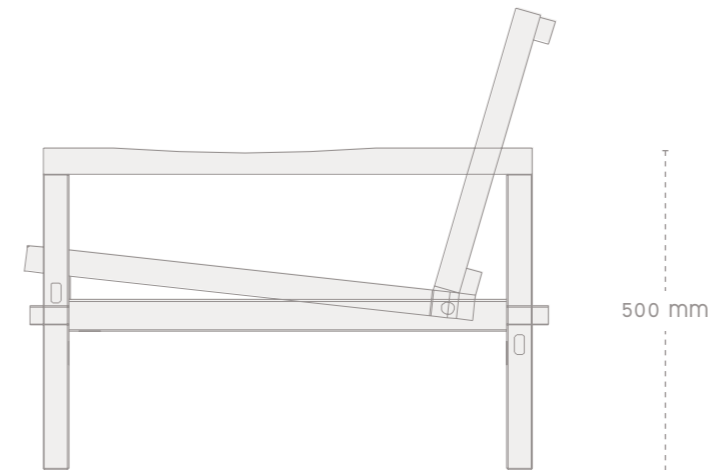
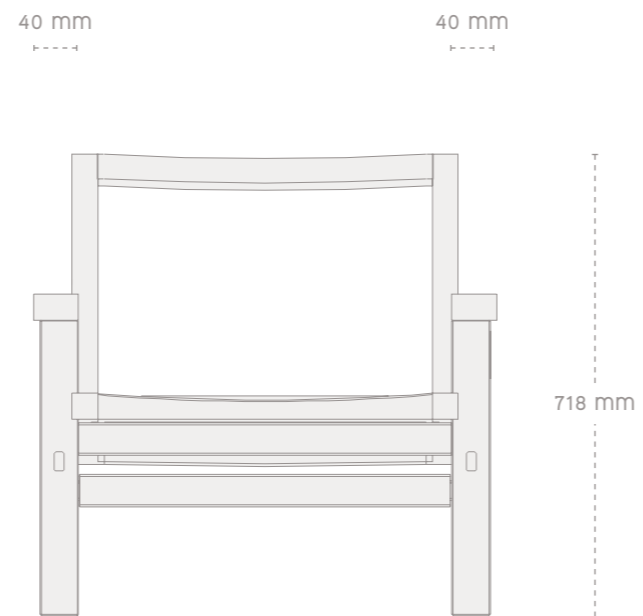
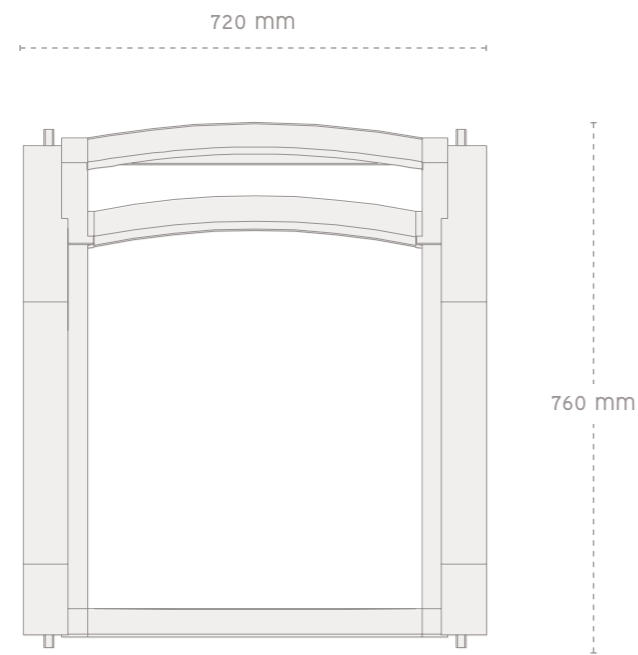

## MEDIDAS

72 cm (L) × 76 cm (D) × 71.8 cm (H)

## MATERIALES

madera sólida de Fresno o Tzalam

+

tejido rattan natural

## ACABADOS DISPONIBLES

aceite — barniz matte — laca negra

# silla 1 XITLE

ADN  
studio

colección volcán

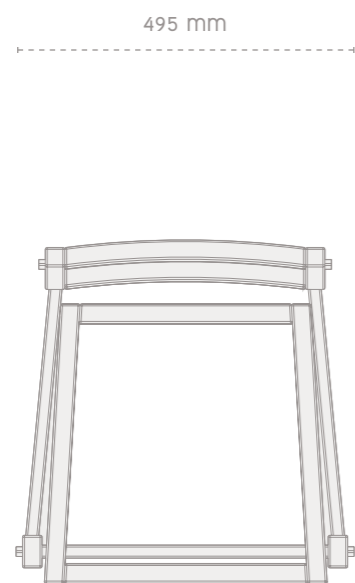

## MEDIDAS

49.5 cm (L) × 50 cm (D) × 78 cm (H)

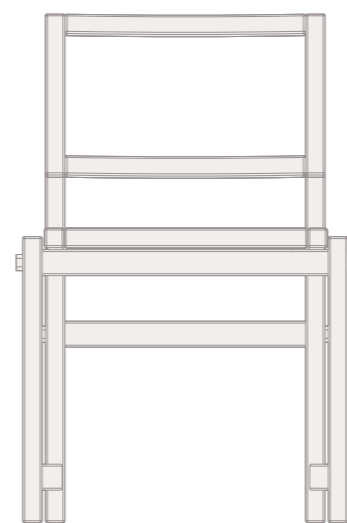

## MATERIALES

madera sólida de Fresno o Tzalam

+

tejido rattan natural

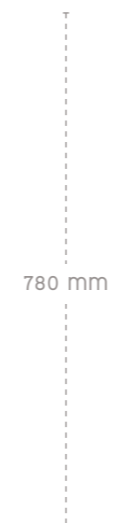

## ACABADOS DISPONIBLES

aceite — barniz matte — laca negra

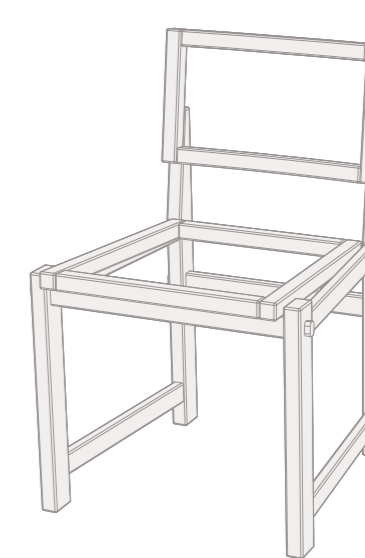
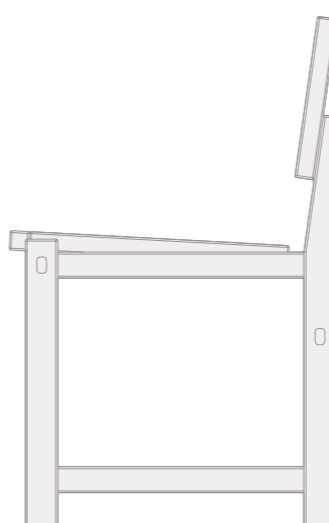

# silla 2 XITLE

ADN  
studio

colección volcán

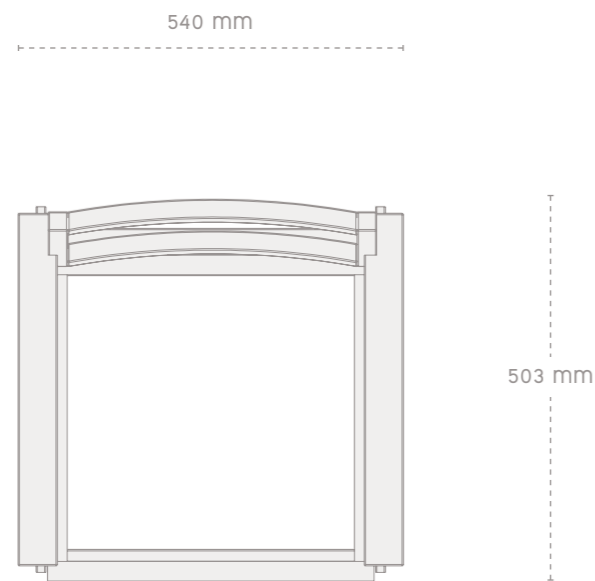

## MEDIDAS

54 cm (L) × 50.3 cm (D) × 78 cm (H)

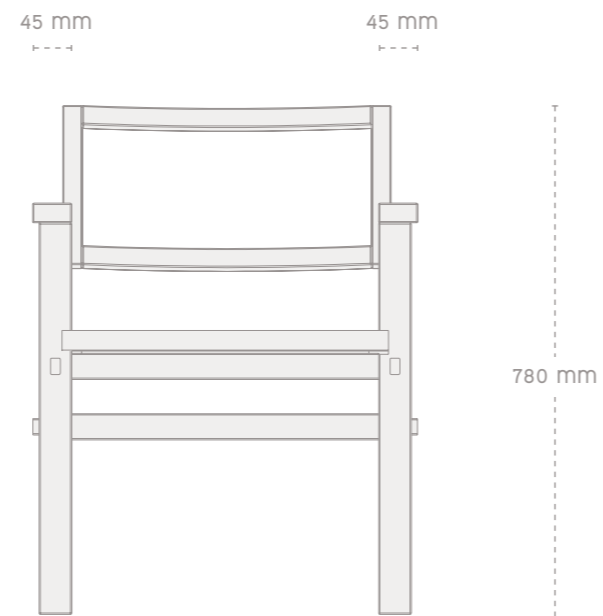

## MATERIALES

madera sólida de Fresno o Tzalam  
+  
tejido rattan natural

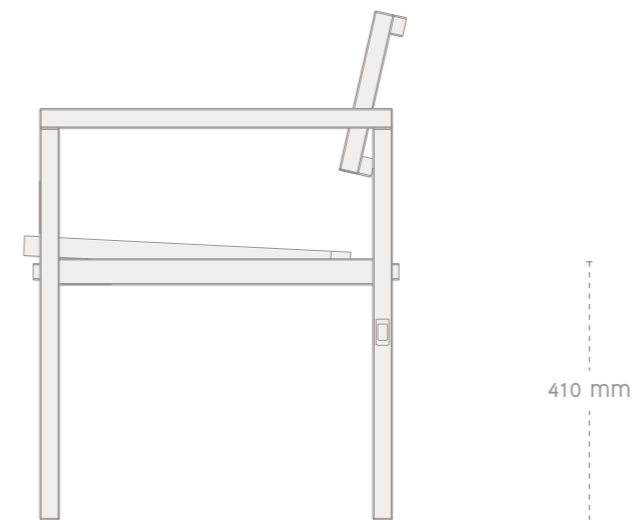

## ACABADOS DISPONIBLES

aceite — barniz matte — laca negra

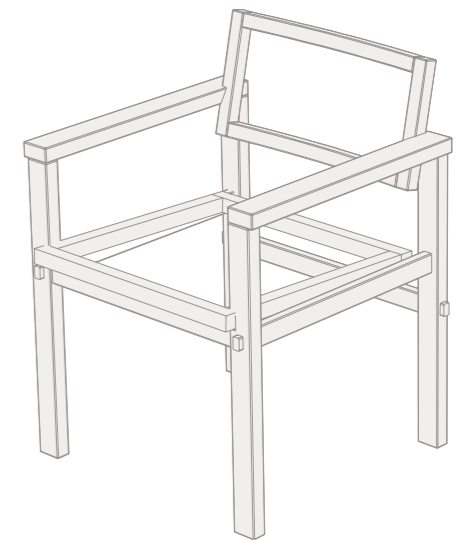

# mesa de centro XITLE

ADN  
studio

colección volcán

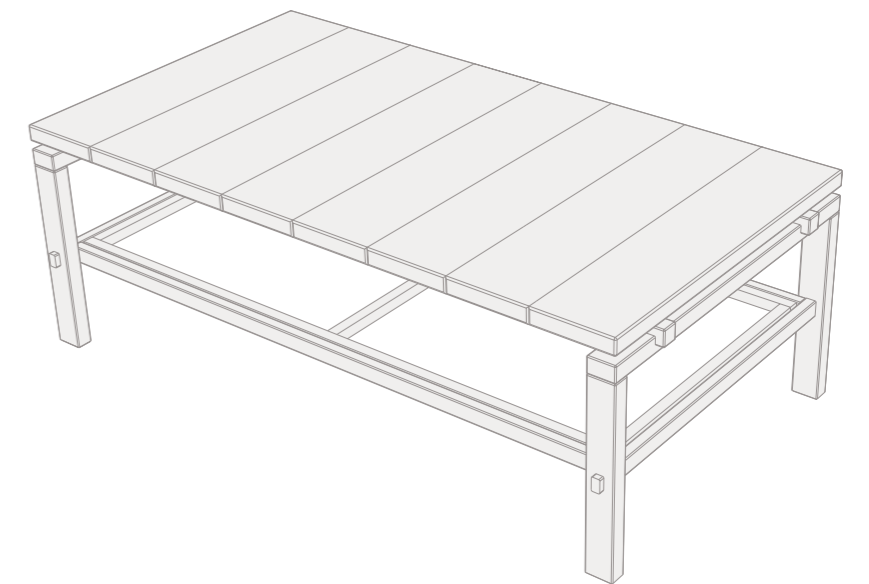
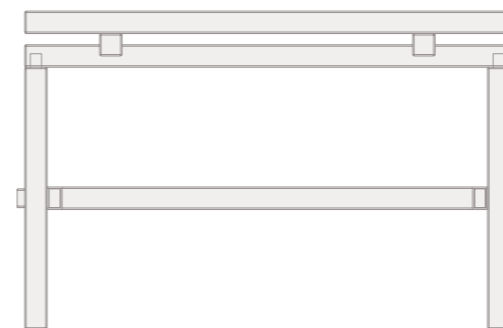
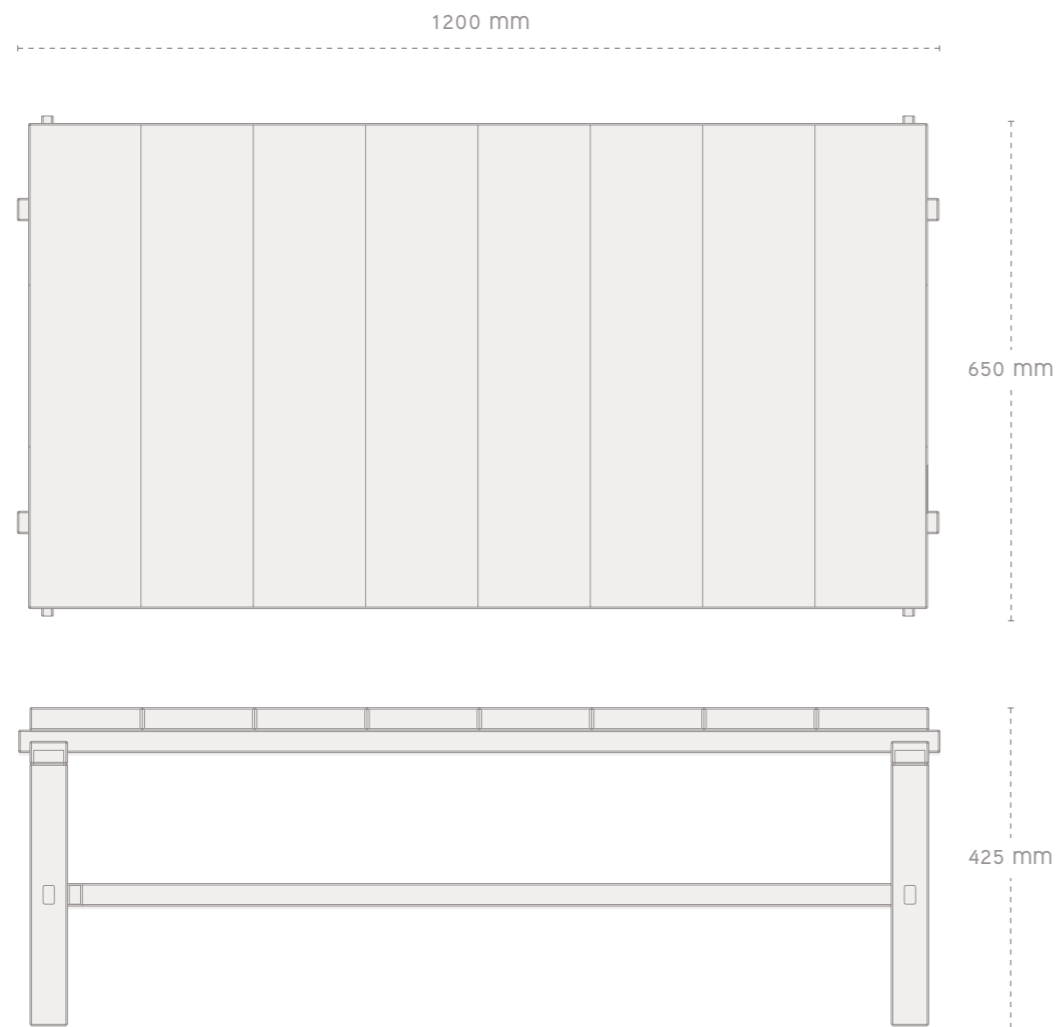

## MEDIDAS

120 cm (L) × 65 cm (D) × 42.5 cm (H)

## MATERIALES

madera sólida de Fresno o Tzalam

+

tejido rattan natural

## ACABADOS DISPONIBLES

aceite — barniz matte — laca negra

# mesa auxiliar XITLE

ADN  
studio

colección volcán

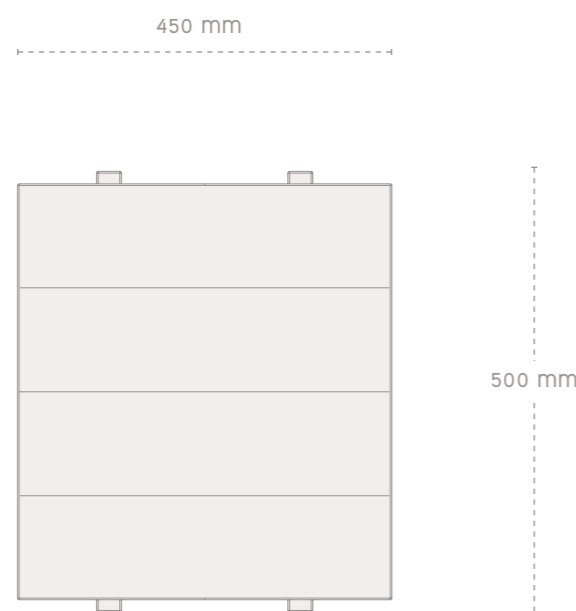

## MEDIDAS

45 cm (L) × 50 cm (D) × 42.5 cm (H)

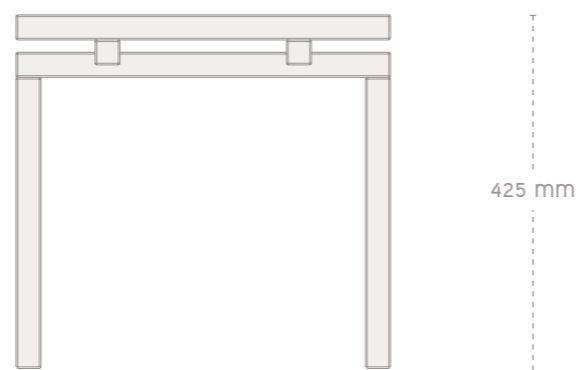

## MATERIALES

madera sólida de Fresno o Tzalam  
+  
tejido rattan natural



## ACABADOS DISPONIBLES

aceite — barniz matte — laca negra

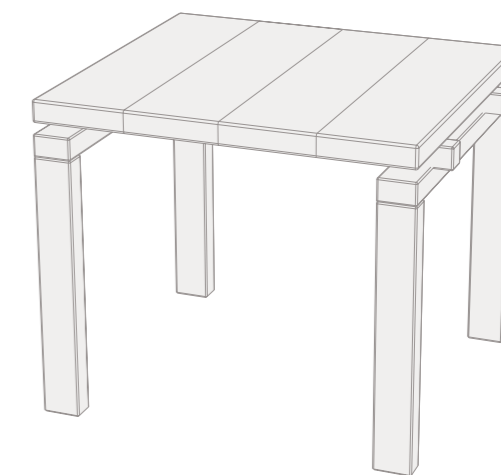

# escritorio XITLE

1800 mm

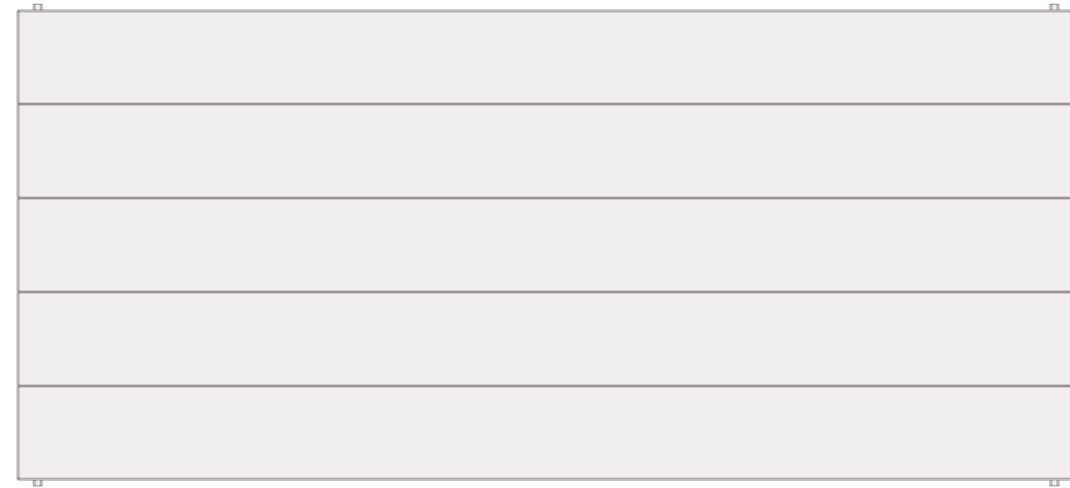

800 mm



750 mm

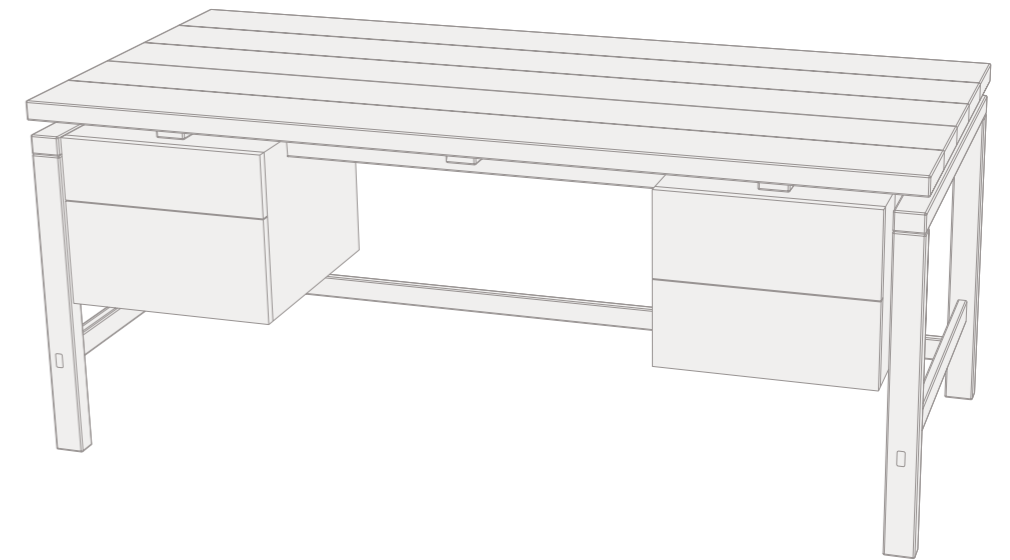
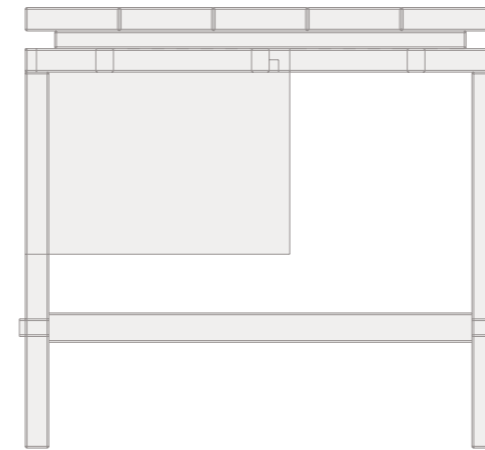

## MEDIDAS

180 cm (L) × 80 cm (D) × 75 cm (H)

## MATERIALES

madera sólida de Fresno o Tzalam

+

tejido rattan natural

## ACABADOS DISPONIBLES

aceite — barniz matte

ADN  
studio

colección volcán



# sillón XITLE

ADN  
studio

colección volcán

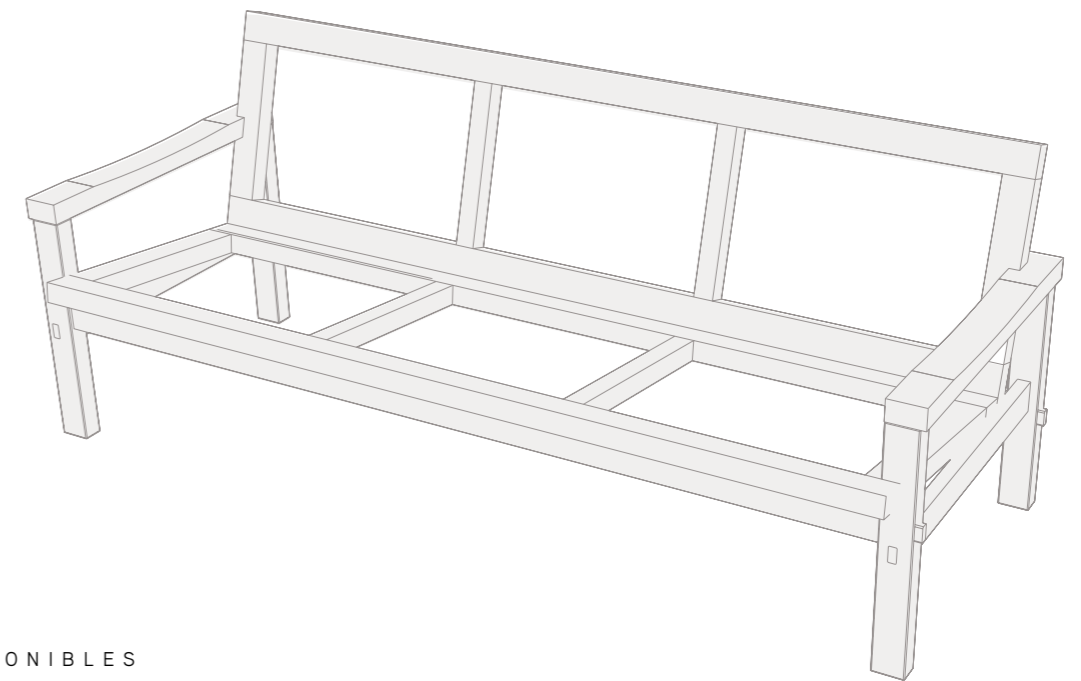
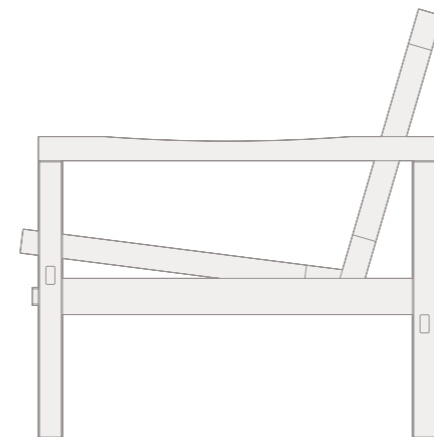
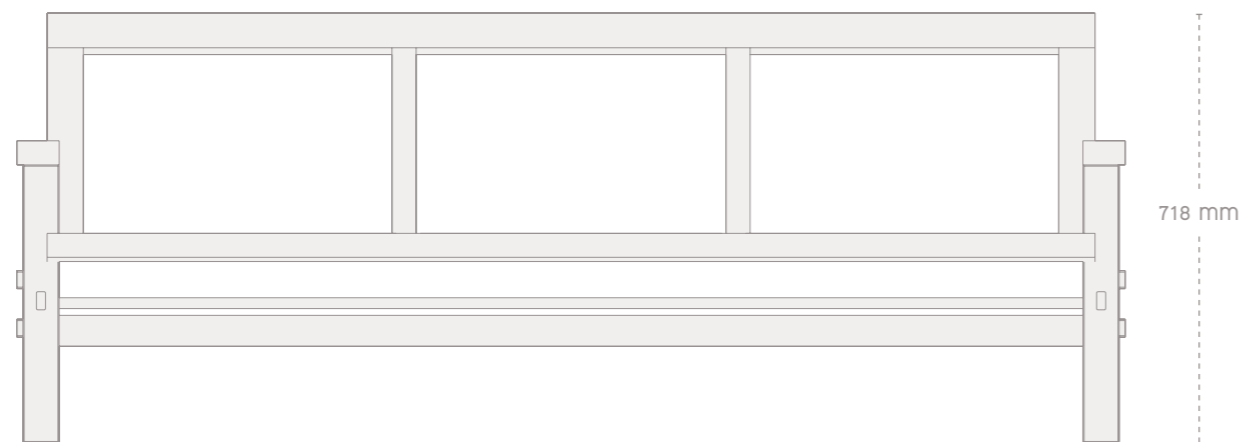

## MEDIDAS

182 cm (L) × 66 cm (D) × 71.8 cm (H)

## MATERIALES

madera sólida de Fresno o Tzalam

+

tejido rattan natural

## ACABADOS DISPONIBLES

aceite — barniz matte — laca negra

# mesa auxiliar TEOCA

ADN  
studio

colección volcán

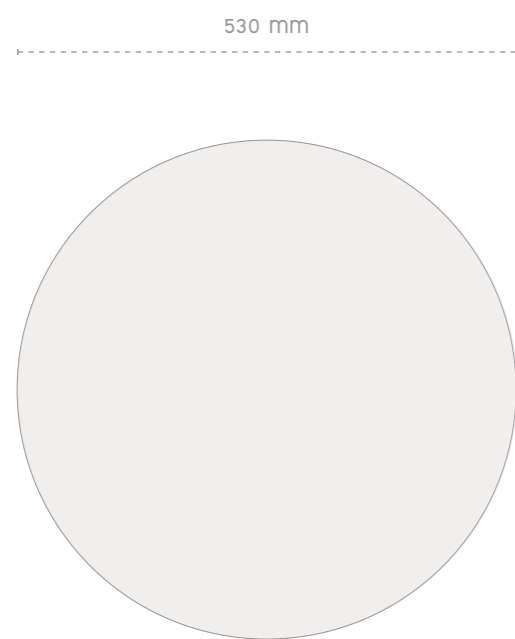

## MEDIDAS

53 cm (DIAM) × 34 cm (H)

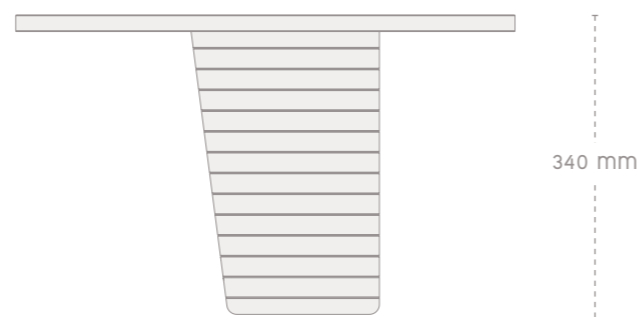

## MATERIALES

madera sólida de Fresno o Tzalam  
+  
cubierta de mármol

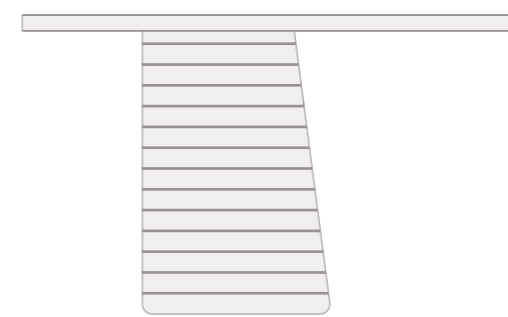

## ACABADOS DISPONIBLES

aceite — barniz matte

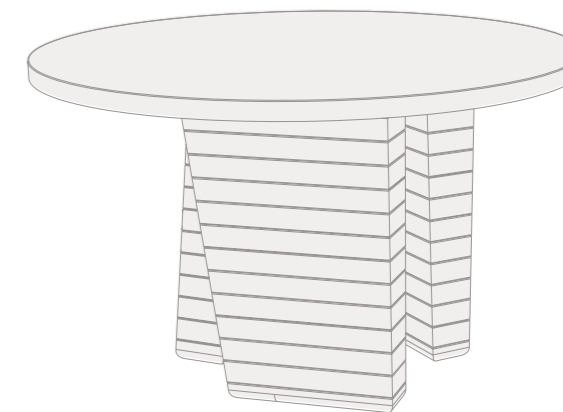

# mesa de centro TEOCA

ADN  
studio

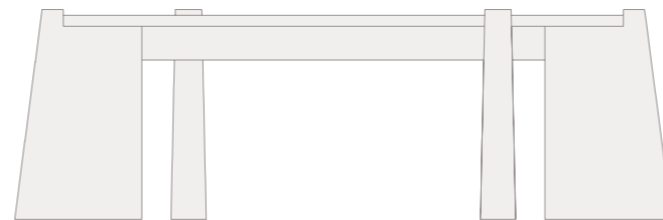
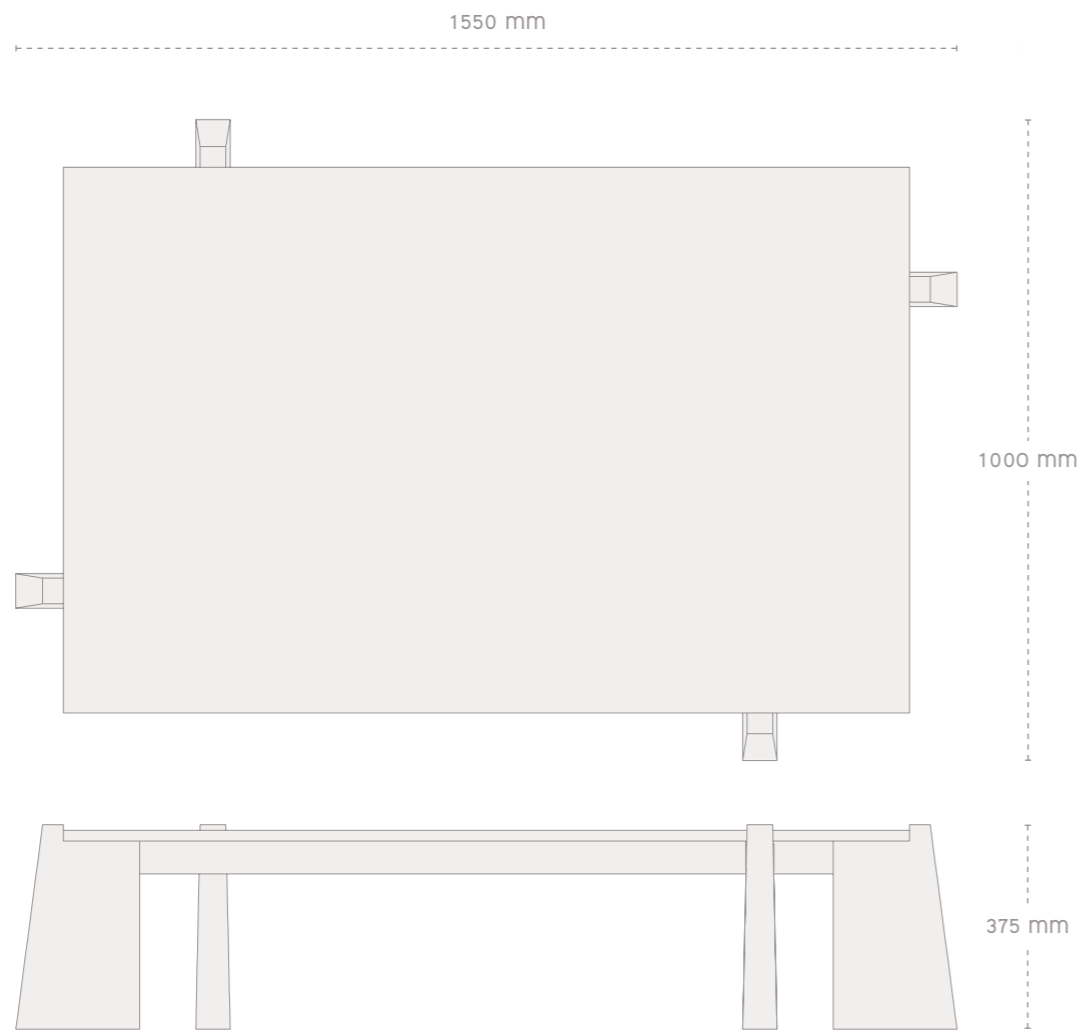

## MEDIDAS

155 cm (L) × 100 cm (D) × 37.5 cm (H)

## MATERIALES

madera sólida de Fresno o Tzalam

+

cubierta de mármol

## ACABADOS DISPONIBLES

aceite — barniz matte

colección volcán

# mesa TEOCA

CHICA / ESCRITORIO: 1800 mm

GRANDE: 2400 mm



CHICA /  
ESCRITORIO:  
900 mm

GRANDE:  
1060 mm



755 mm

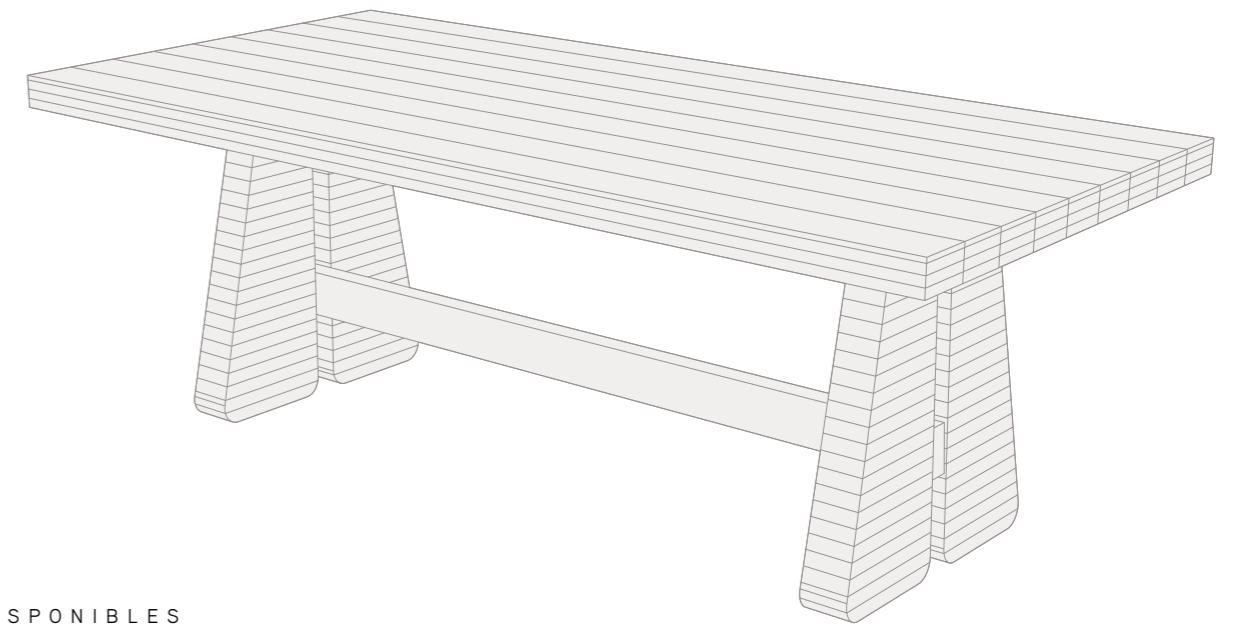
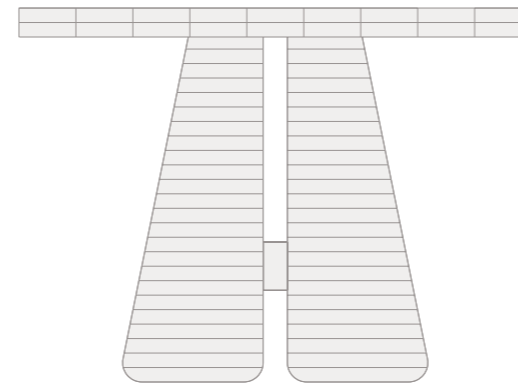

## MEDIDAS

chica / escritorio: 180 cm (L) × 90 cm (D) × 75.5 cm (H)

grande: 240 cm (L) × 106 cm (D) × 75.5 (H)

## MATERIALES

madera sólida de Fresno  
o Tzalam

## ACABADOS DISPONIBLES

aceite — barniz matte

ADN  
studio

[info@adn-galeria.com](mailto:info@adn-galeria.com)

NUESTRO AGRADECIMIENTO A: